

Acoustic



Installation guide

Installation Guide

Acoustic mycelium-based products

Mogu Acoustic collection marks an unprecedented revolution for interior design comfort. Mogu Acoustic are the first commercially available products of their kind, entirely made of fungal mycelium and of upcycled textile residues. Thanks to the unique technology, Mogu Acoustic panels represent today the most sustainable solution dedicated to acoustic comfort. Please check our Care & Instructions Manual for detailed information about correct product handling.

TABLE OF CONTENTS

General Introduction	p.3
Product Information	p.4
WAVE	p.4
KITE	p.6
FIELDS	p.8
ASPEN / FORESTA	p.10
Glue installation	p.12
Screw-based installation	p.13
Magnet-based installation	p.14
Fastening Straps installation	p.16
Ceiling installation	p.17
Care & Instructions	p.19

Models

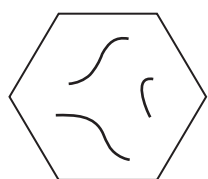

WAVE

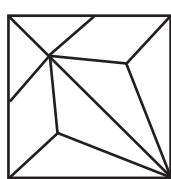

KITE

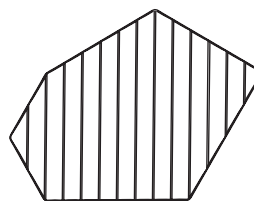

FIELDS



ASPEN / FORESTA

General Introduction

Nature's technology

We hope you are satisfied with your new Mogu product. It was (grown and) made in Italy, out of low value residues and the most advanced mycelium technology, with the lowest possible environmental impact. Mogu Acoustic panels are the result of transformation processes which have as input biological materials; Mogu attentively carries out such transformations, thanks to its advanced technical protocols, derived by Nature and crafted with the utmost care. Despite Mogu's best efforts, due to the very nature characterizing biological materials, our products may bear slight differences from the reference standard pattern seen in reference images. Small imperfections, such as color differences and irregular edges or surface should be considered as inherent value, deriving from employing Nature's finest technologies.

Arrival & Installation

Mogu Acoustic panels are delivered ready to mount, as in your preferred solutions for fixing. Mogu products are dimensionally stable, so they can be installed immediately after arrival. Upon delivery, open the boxes and inspect the products immediately. Eventual damages should be reported to Mogu immediately. If installation happens days after delivery, make sure to leave the boxes open, stored in original packing in a clean, climate controlled environment free of moisture. Handling of Mogu products should happen with the utmost care, not imposing any force into the material. Wall & ceiling surface where you install Mogu products should be clean and free of dust. Never install Mogu products on surfaces subject to humidity or on recently painted surfaces; paint should dry at least a week before installation.

Product handling

We recommend avoiding cutting and general manipulation of Mogu Acoustic panels. Mogu declines any responsibility for product performance (acoustics, fire and all declared properties) after alteration. However, if required by your project, cutting of Mogu Acoustic products is possible with standard saws. Best results can be achieved with circular saw with a large number of teeth (minimum 96). Exposed edges can be finished with touch up paint or spray-on commercial glues, to keep fibers from falling off.

We recommend contacting our Support Team (support@mogu.bio) to receive suggestions concerning the cutting methodology and touch-up painting afterwards, to ensure the best results. Do not screw into the panels or use any other fixing system rather than the ones recommended by Mogu's installation guidelines. Mogu bears no responsibility for properly checking the environment and surface conditions where the products are installed. The responsibility for the evaluation of potential issues and compensating for different field conditions is with the installer. You are welcome to contact us at support@mogu.bio for inquiries concerning installation & products handling.

Dimensions & weight

	w* [mm]	h* [mm]	t* [mm]	side* [mm]	sqm	n°/sqm	weight [Kg]
WAVE	560	485	25-75	280	0.2	5	1.1
KITE	500	500	35-75	500	0.25	4	1.5
FIELDS	760	535	45	210	0.25	4	1.5
PLAIN 50	500	500	40	500	0.25	4	1.2
PLAIN 60	600	600	40	600	0.36	2.78	1.4
PLAIN 6040	600	400	40	600	0.24	4.17	1.2
ASPEN / FORESTA	455	398	65	455	0.11	11	0.6

* Mogu panels may present slight dimensional variations as they are subject to the tolerances of the natural production process that characterise and enhance Mogu's products. However Mogu carries out a dimensional control to ensure a dimensional variation of maximum +/- 4 mm.

Product Information

WAVE

The WAVE model is available in Hexagon shape, allowing for different typologies of compositions and arrangements. The soft waves and the geometric edges allow for multiple configurations in all directions, creating a wall that generates the sensation of wandering through hills covered in fresh snow. Mogu Wave can be installed as a single panel or as a composition. To maximize its aesthetic effect, we suggest dispositions that resemble clouds.

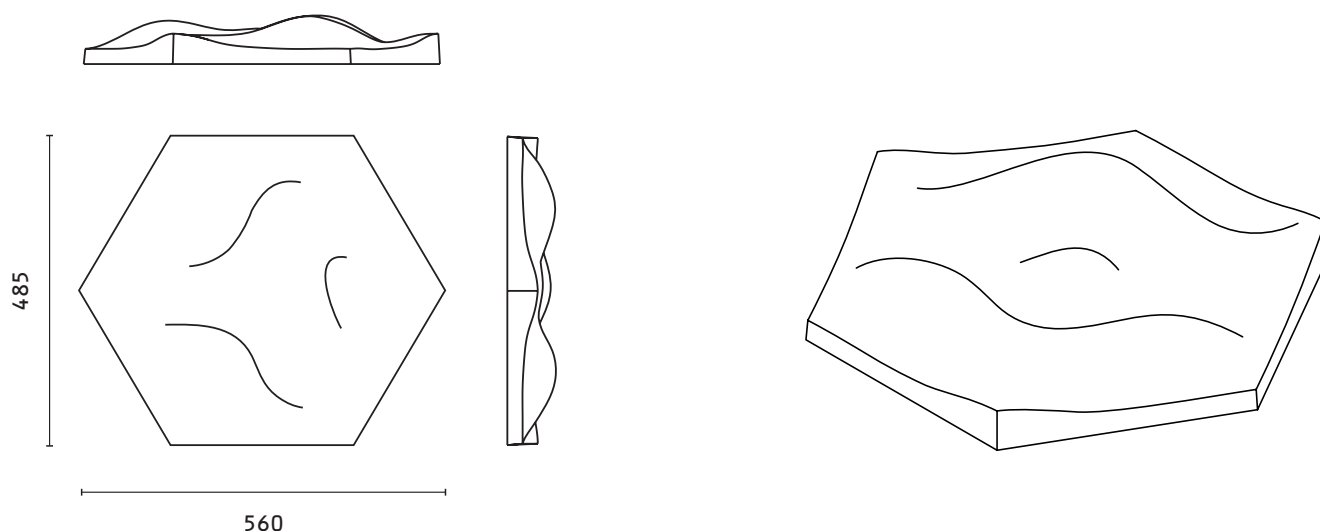

Dimensions & weight

	w* [mm]	h* [mm]	t* [mm]	side* [mm]	sqm	n°/sqm	weight [Kg]
WAVE	560	485	25-75	280	0.2	5	1.1

* Mogu panels may present slight dimensional variations as they are subject to the tolerances of the natural production process that characterise and enhance Mogu's products. However Mogu carries out a dimensional control to ensure a dimensional variation of maximum +/- 4 mm.

Packing Info

PACKING	W	L	H	VOLUME	WEIGHT	N° PANELS	SQM
	mm	mm	mm	cbm	kg	pcs/unit	sqm/unit
BOX	600	540	470	0.15	8.5	5 pcs/box	1 sqm/box
PALLET 80120*	800	1200	2000	1.92	80	40 pcs/pal.	8 sqm/pal.

* Actual packing size might vary depending on the fixing system chosen.

Arrangement examples

Mogu Wave features three thicker edges that, once aligned with adjacent modules, form a wavy pattern. By rotating the Hexagons, you can easily find edge correspondence, as it is shown in the graphic on the right. Mogu Wave panels can be arranged in a full composition, as shown below, or in an open layout. Mogu panels are dimensionally stable, thus you are free to choose the preferred distance among the panels.

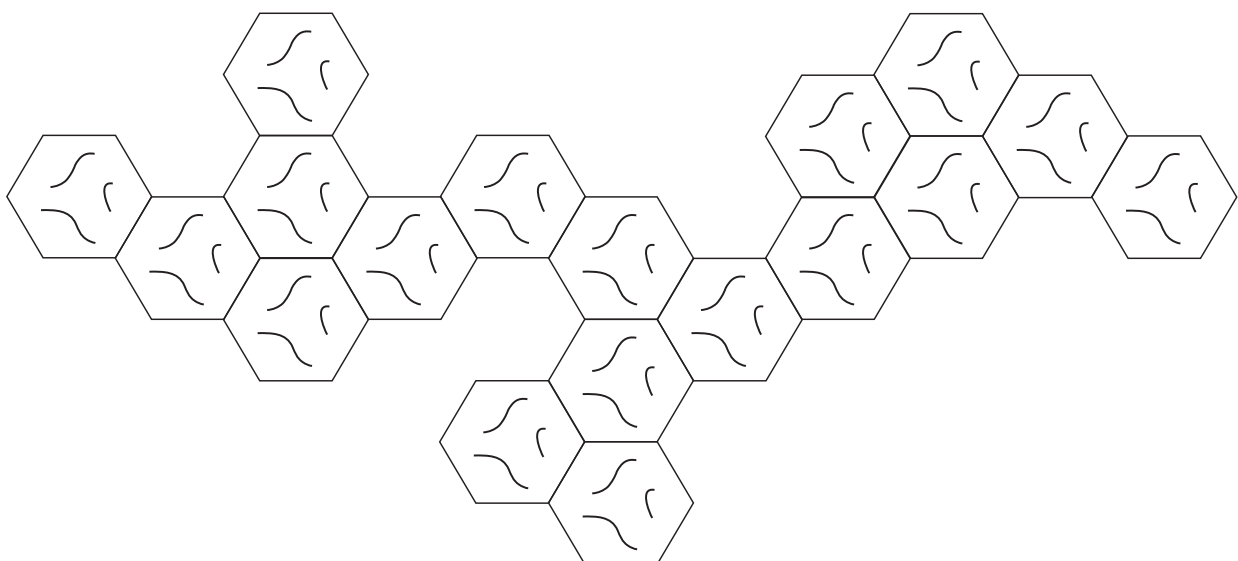
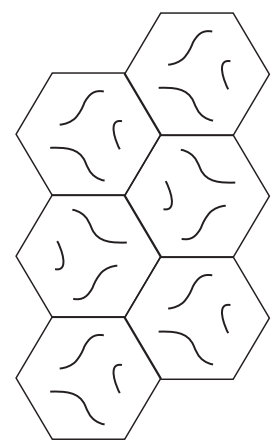
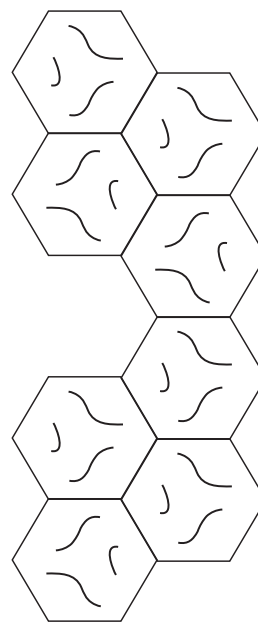
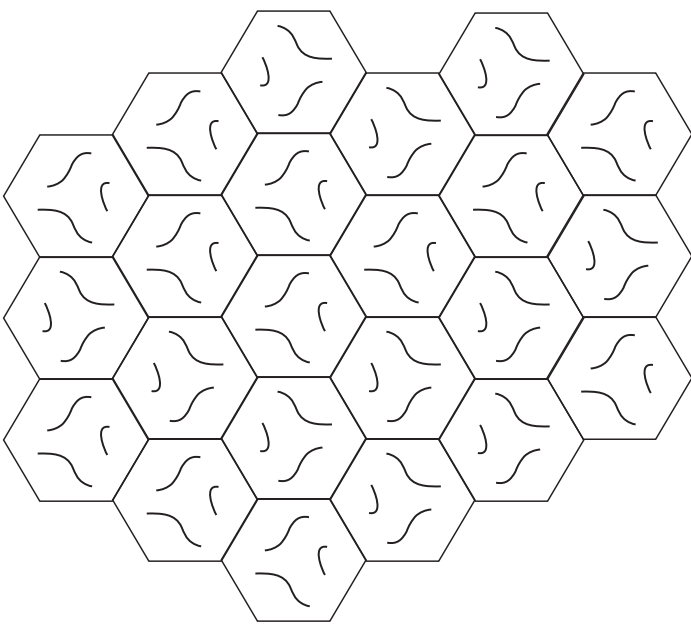
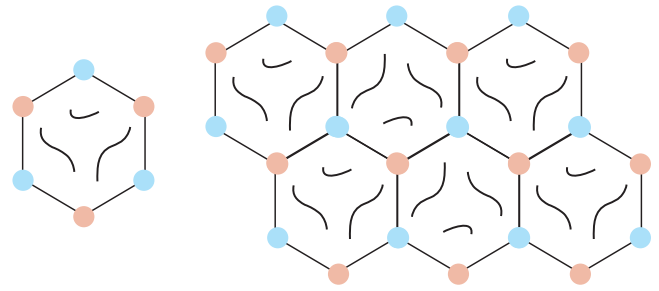

Product Information

KITE

The Kite panel is inspired by the interplay between light and the candid surface of mycelium materials. The geometric folds create a visual pattern through shadows and highlights, in a play of contrasts with the softness of Mogu materials.

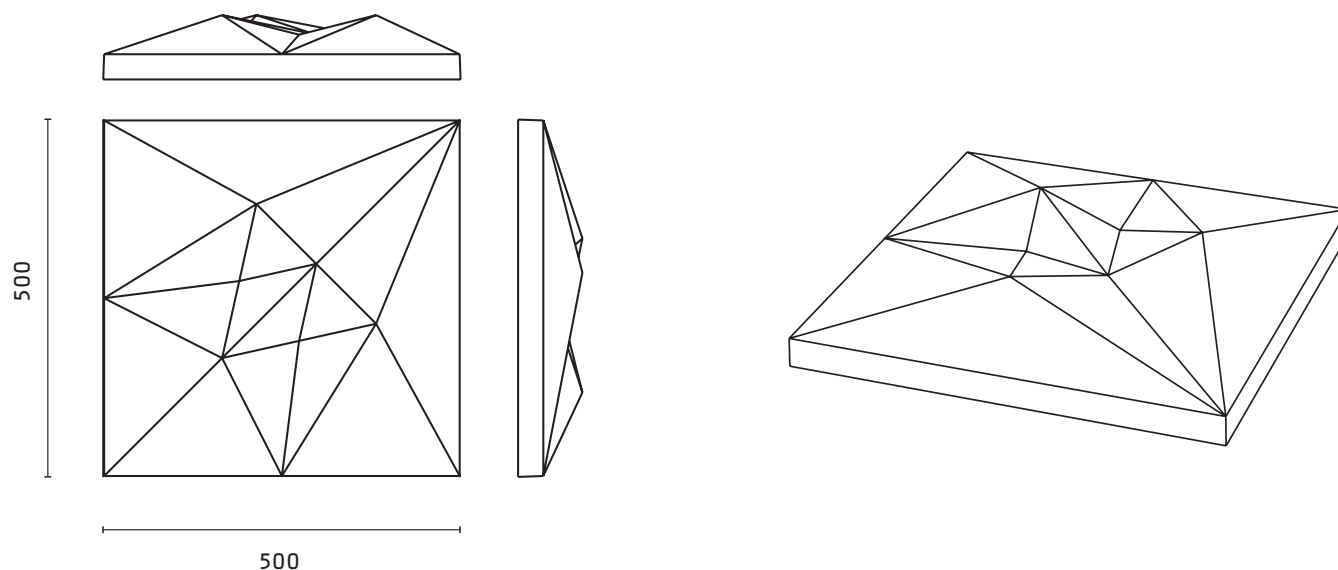

Dimensions & weight

	w* [mm]	h* [mm]	t* [mm]	side* [mm]	sqm	n°/sqm	weight [Kg]
KITE	500	500	35-75	500	0.2	5	1.5

* Mogu panels may present slight dimensional variations as they are subject to the tolerances of the natural production process that characterise and enhance Mogu's products. However Mogu carries out a dimensional control to ensure a dimensional variation of maximum +/- 4 mm.

Packing Info

PACKING	W	L	H	VOLUME	WEIGHT	N° PANELS	SQM
	mm	mm	mm	cbm	kg	pcs/unit	sqm/unit
BOX	600	540	470	0.15	8.5	4 pcs/box	1 sqm/box
PALLET 80120*	800	1200	2000	1.92	80	32 pcs/pal.	8 sqm/pal.

* Actual packing size might vary depending on the fixing system chosen.

Arrangement examples

Kite modules feature two sides with a midpoint fold (pink dots) and two adjacent sides without (blue dots). By matching these reference points, the panels form a playful and surprising geometric pattern, shown at its best with the interplay of light and shadows. The composition can be arranged as square tile, or as diamond tiling.

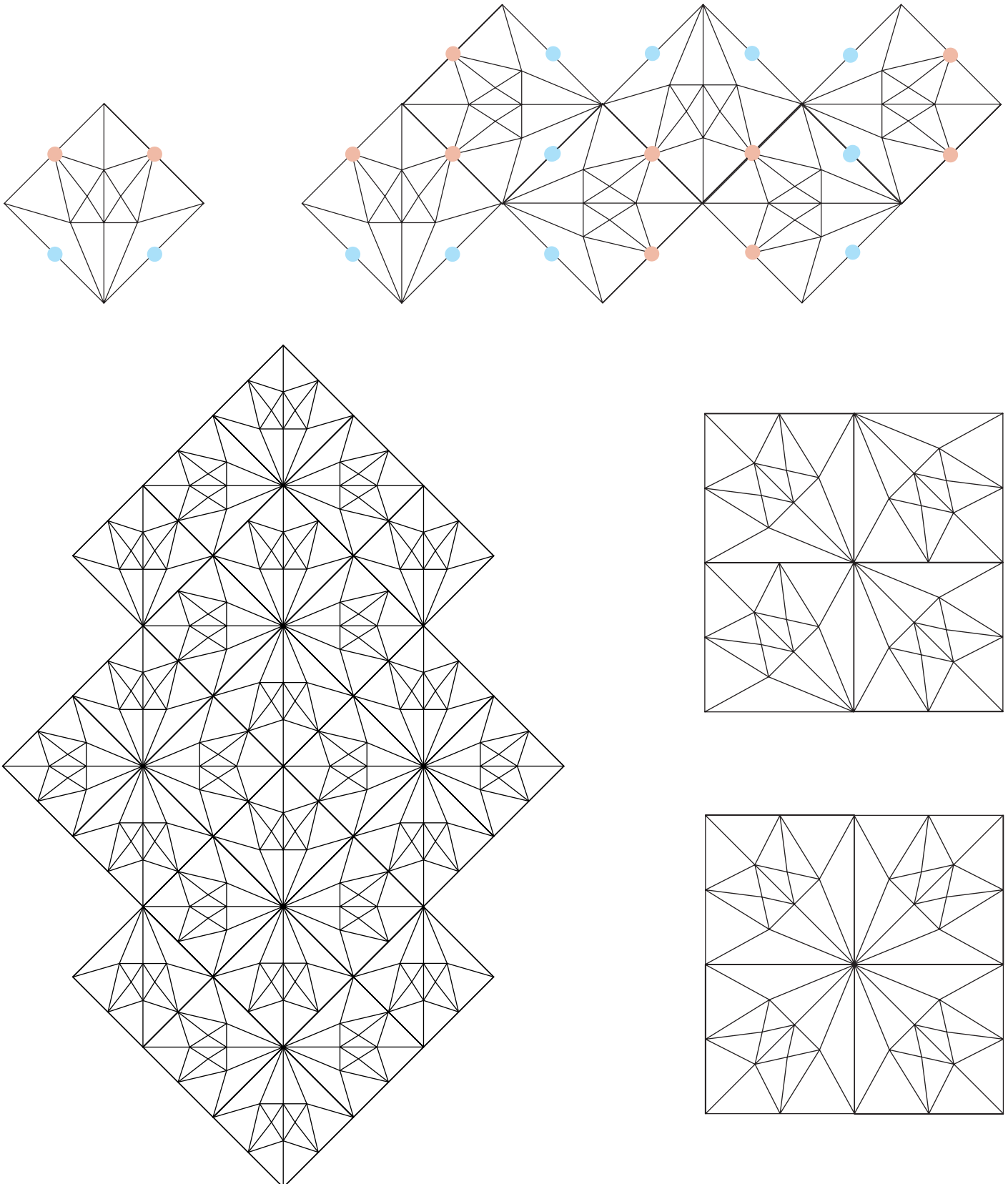

Product Information

FIELDS

Inspired by the patches of cultivated land as seen from above, Mogu Fields features an irregular hexagon shape. Its soft, velvety surface is marked by delicate stripes, recalling the pattern of the seeding tracks. A calm texture, evoking the long-lasting collaboration between Humans and Nature.

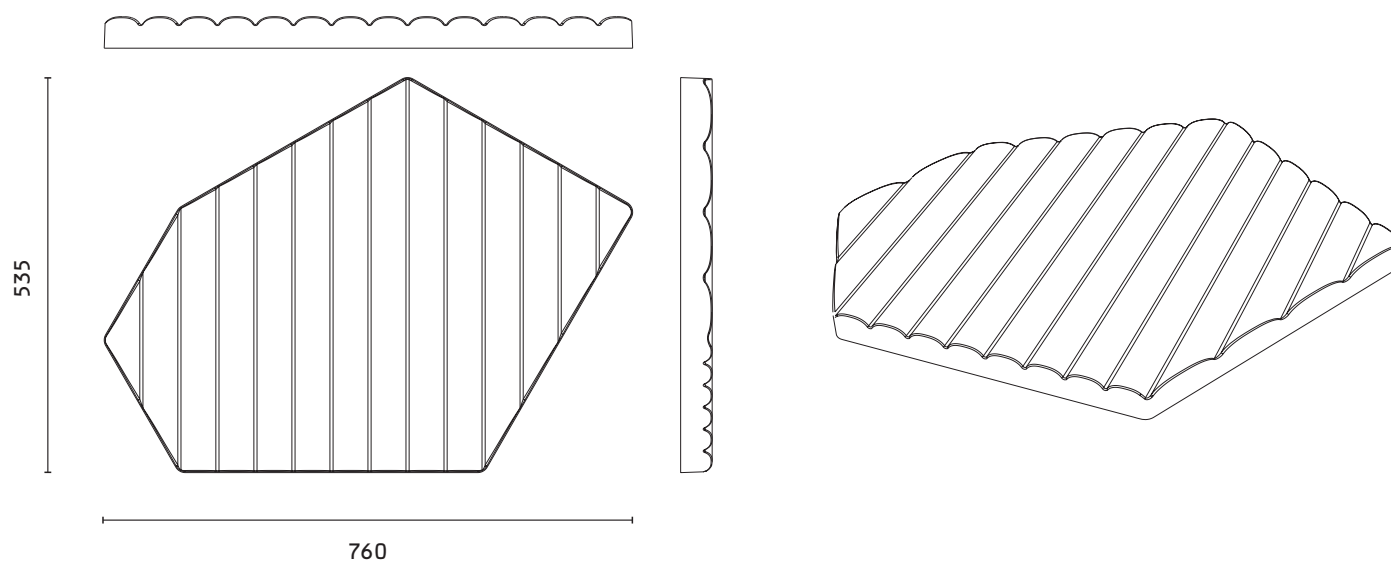

Dimensions & weight

	w* [mm]	h* [mm]	t* [mm]	side* [mm]	sqm	n°/sqm	weight [Kg]
FIELDS	760	535	45	210	0.25	4	1.5

* Mogu panels may present slight dimensional variations as they are subject to the tolerances of the natural production process that characterise and enhance Mogu's products. However Mogu carries out a dimensional control to ensure a dimensional variation of maximum +/- 4 mm.

Packing Info

PACKING	W	L	H	VOLUME	WEIGHT	N° PANELS	SQM
	mm	mm	mm	cbm	kg	pcs/unit	sqm/unit
BOX	725	565	270	0.11	9	4 pcs/box	1 sqm/box
PALLET 80120*	800	1200	1750	1.68	120	48 pcs/pal.	12 sqm/pal.

* Actual packing size might vary depending on the fixing system chosen.

Arrangement examples

Though irregularly shaped, Mogu Fields modules allow for a perfect tiling by means of simple rotation of its geometry on one side. For a regular composition, please find below the guidelines on the correct alignments of edges. When adjacent, as in their standard configuration, the lines will always meet each other, creating a visually ordered and elegant pattern. Mogu Fields can be arranged without any distance among the panels, or with 5-10 cm space, according to your aesthetic preference.

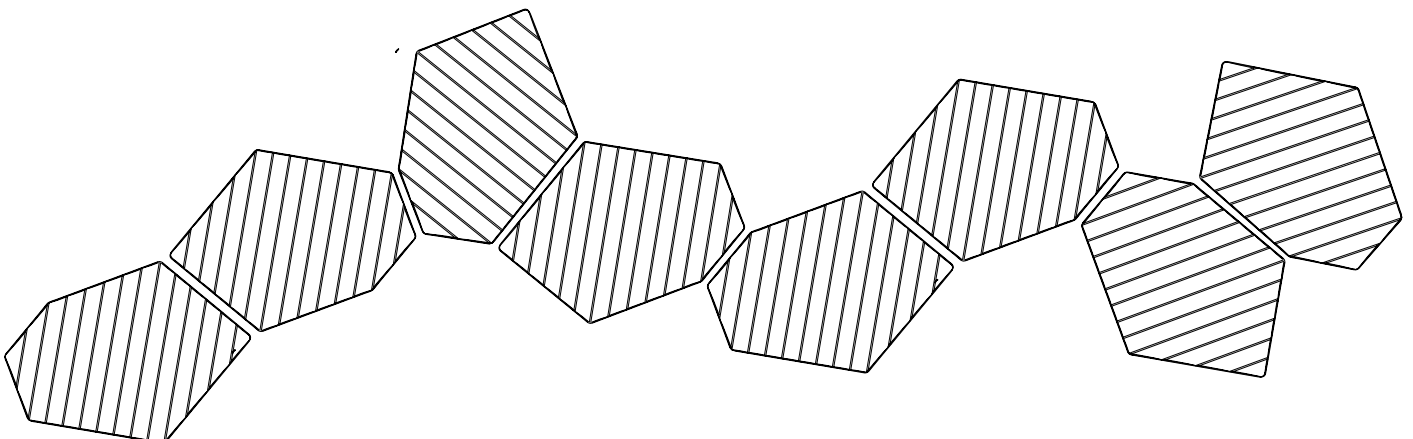
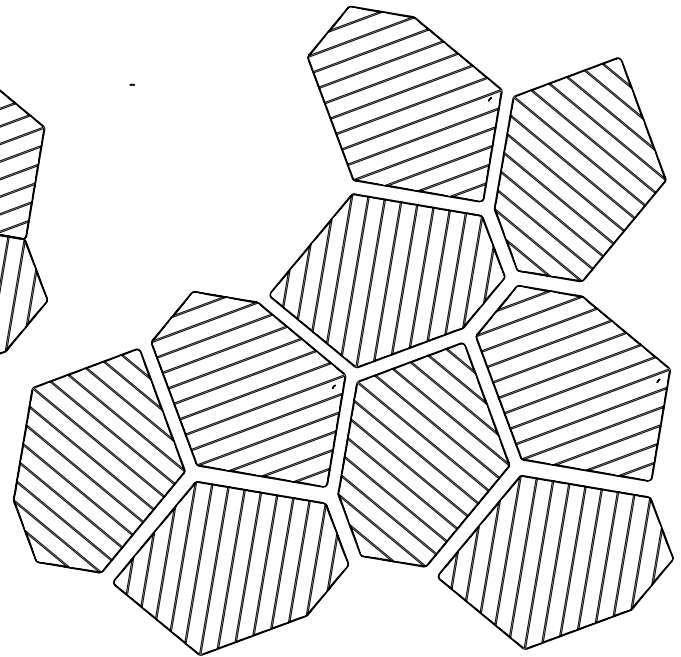
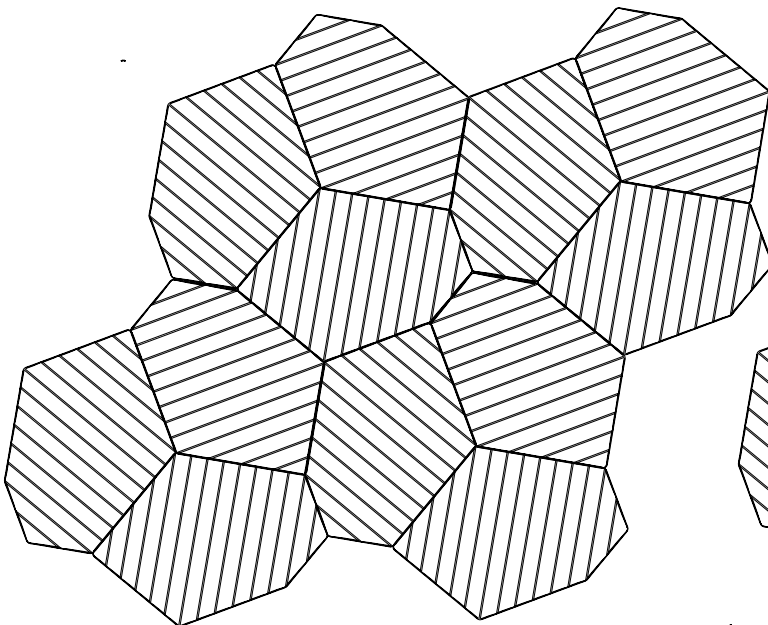
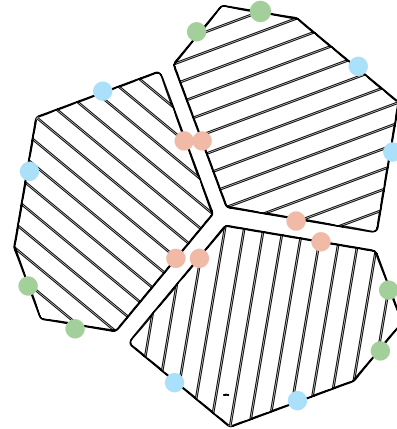
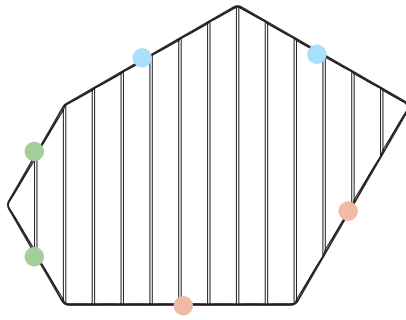

Product Information

ASPEN / FORESTA

The number "three" in Nature lies at the heart of every proportion. Mogu Aspen panels are small triangles that allow for maximum design flexibility. They have been designed for our brand new Foresta system – make sure to check our detailed Installation Guide! Nevertheless, Mogu Aspen panels are designed to be installed also with our standard fixing system, for wall or ceiling.

Dimensions & weight

	w* [mm]	h* [mm]	t* [mm]	sqm	n°/sqm	weight [Kg]
ASPEN	455	398	65	0.11	11	0.6

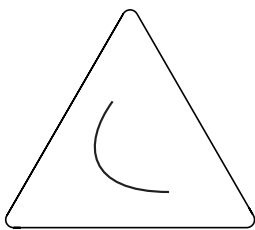

AA - CONCAVE

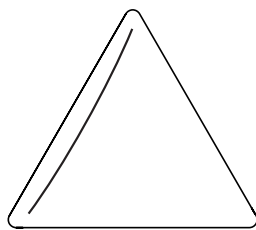

AB - CONVEX

ASPEN with FORESTA SYSTEM

The FORESTA system is based on a refined combination of wood batten ("branches") and "nodes". The wood battens are designed to be mechanically fixed to the wall, requiring a minimal amount of wall-perforations. The nodes simply hold onto the rails and, thanks to the integrated magnets, allow for an easy-to-mount approach in regard to the mounting of the ASPEN acoustic modules.

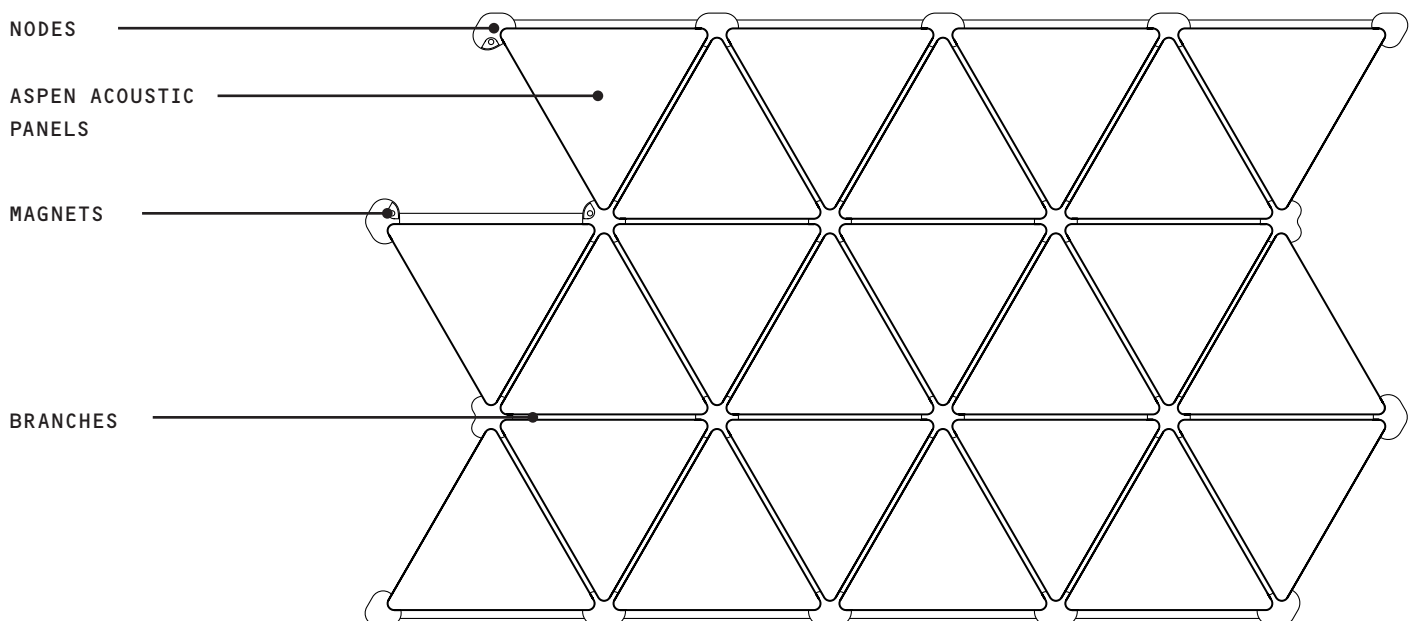

* Mogu Acoustic panels may present slight dimensional variations as they are subject to the tolerances of the natural production process that characterise and enhance Mogu's products. However Mogu carries out a very strict dimensional control to ensure as little dimensional variation as possible.

Arrangement examples

With the node establishing a consistent formal language, translating between the substrate of the wall and the panels, FORESTA modular system allows and encourages to (re)configure and customize the pattern. Thanks to Mogu's unique colour palette, it is possible to choose from a range of colour themes.

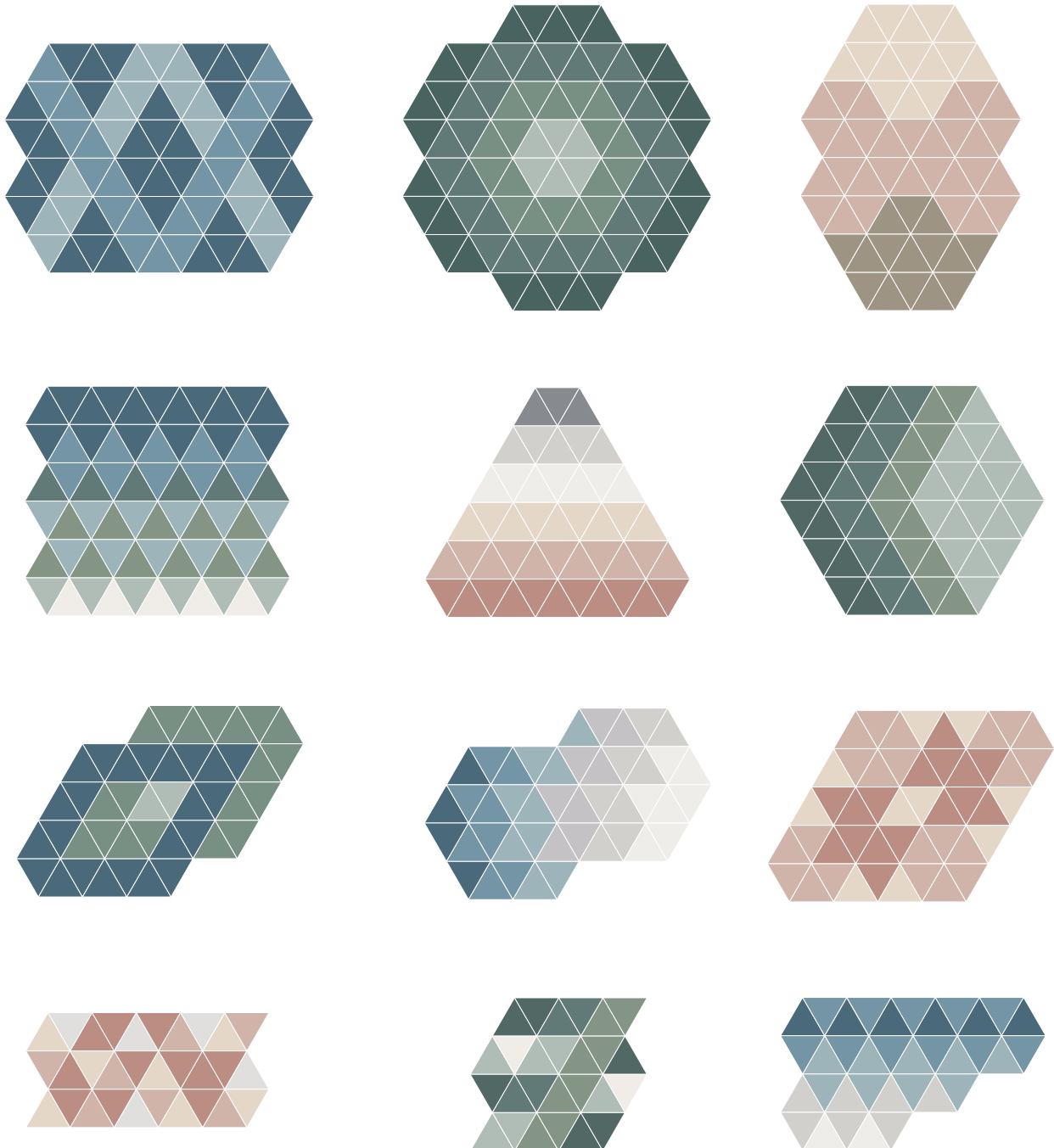

Glue Installation

Glue application

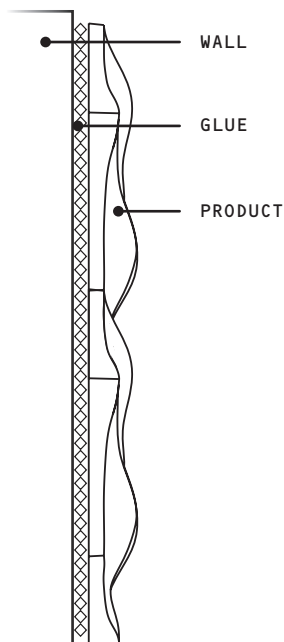

Mogu Acoustic panels can be installed with any commercially available glue, suitable for generic type of materials. For wall applications, Mogu recommends using VIGOR Glue 'Nails stop', while for ceilings, Tytan 'Fast&Strong' is the recommended choice. Make sure to distribute a sufficient amount of glue on the panel as shown below. Distribute the glue close to the edges, leaving 2-3 cm of distance, so that when force is applied, the glue will not seep out of the panel.

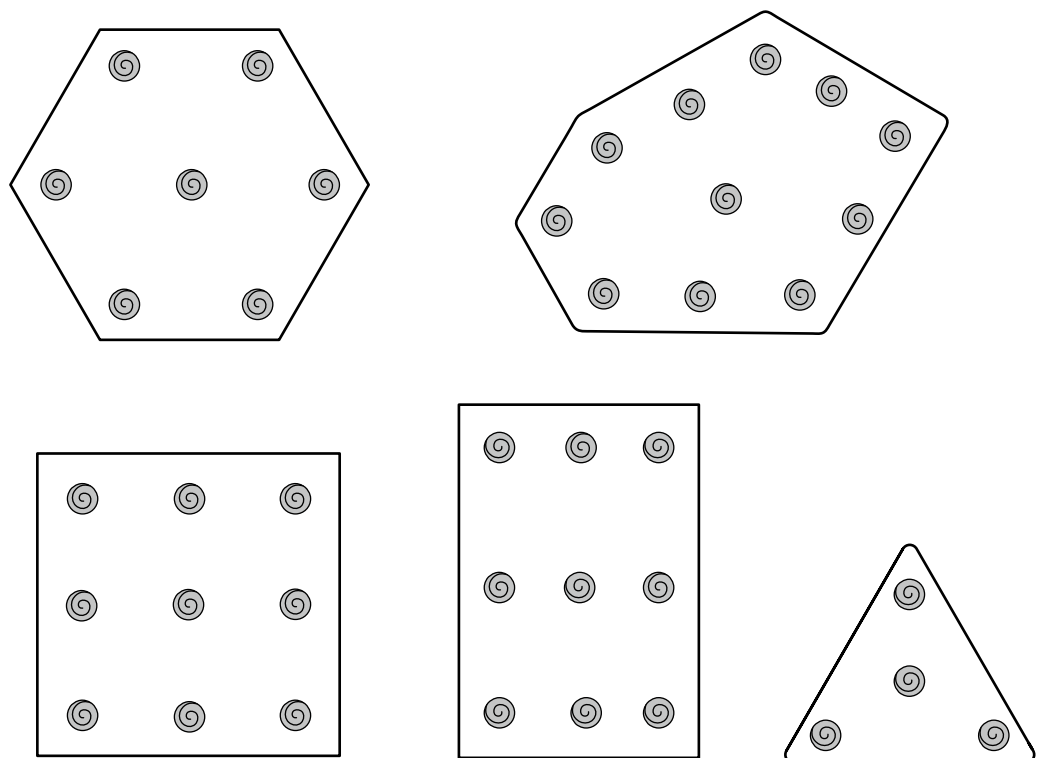

Guidelines

Before starting, read and follow the General Instructions in this document, the guidelines for Glue application and the Care & Maintenance Instructions available on Mogu website.

1. Test your composition on a clean floor, choosing your favorite arrangement;
2. Use a level to establish a cross-line at the centre of your wall;
3. Place the first panel without applying too much force and use the level to check squareness of alignment;
4. Press force over the material gently, better if using the wrapping paper provided in Mogu packing;
5. You can now continue with your composition by simply taking the side of each hexagon as reference!
6. Make sure to use the level for each product, in order to check squareness.

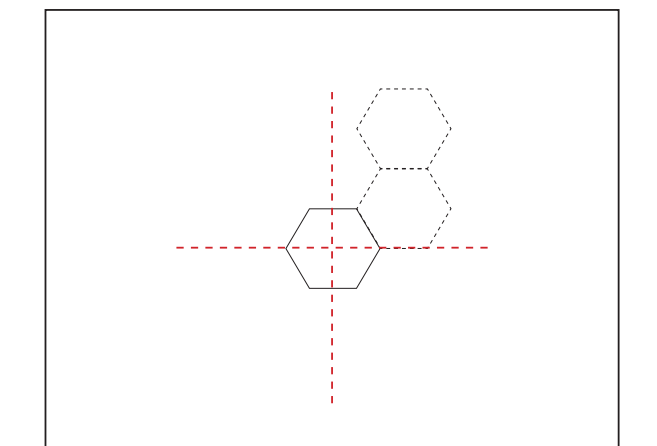

Screw-based Installation

Z-clips fixing system

To provide you with a simple, mechanical fixing, we choose an easy and commercially available solution called z-clips. This system is composed by two parts: the long one, to be fixed directly to the wall and the second one, already applied on our panels. Each acoustic model presents the z-clips in different positions, depending on the composition chosen.

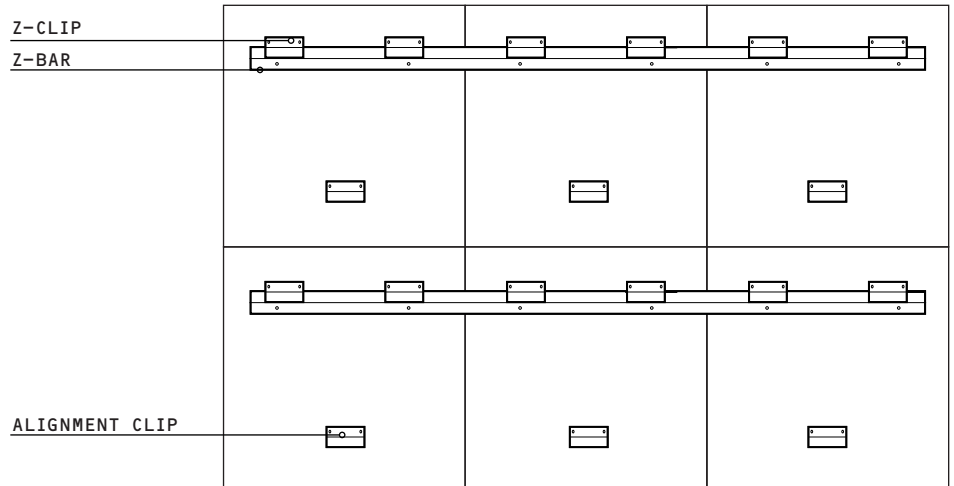
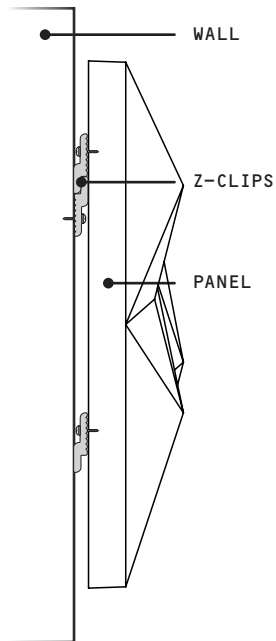

Guidelines

Before starting, read and follow the General Instructions in this document, the guidelines and the Care & Maintenance Instructions available on Mogu website.

1. Carefully, lay two panels on the floor with the back side facing up. Take two z-bars and fit them into the topmost row of each panel. At this stage, take the distance **D** (see image A.), you will need it for the next step.
2. Start at the bottom and fix the first z-bar to the wall. Checking the alignment by using a level;
3. Fix the second z-bar at the same distance **D** taken just before. N.B. At this point it is recommended to install two panels and check if the z-bar distance is correct.
4. You can now install all the panels and reach your final composition!

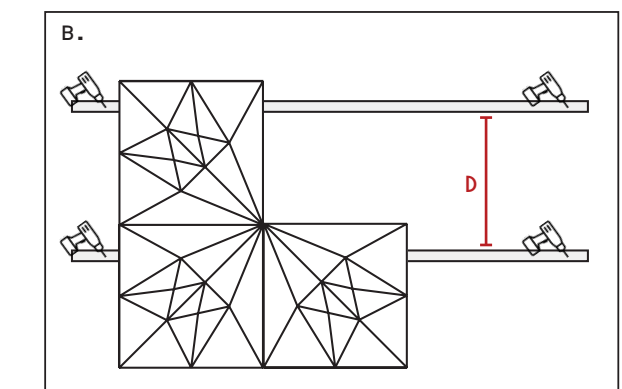
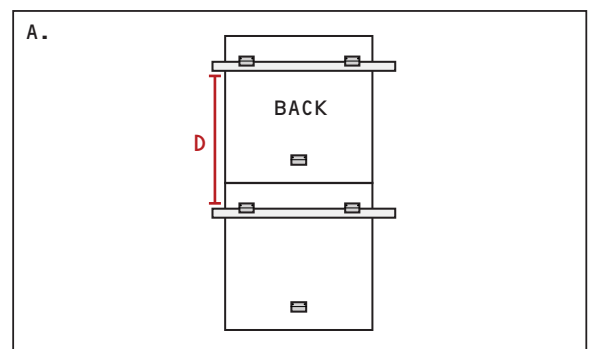

Magnet-based Installation

Magnetic fixing system

Mogu's exclusive fixing system is designed specifically for Mogu products. When you choose the magnet-based option, Mogu products will arrive already equipped with the fixing system, in the standard configuration as below. On the back of the panel are mounted two metal plates with magnets. On the wall, if you do not have a metallic surface, you can order a special steel grid provided by Mogu.

OPTION 1 //

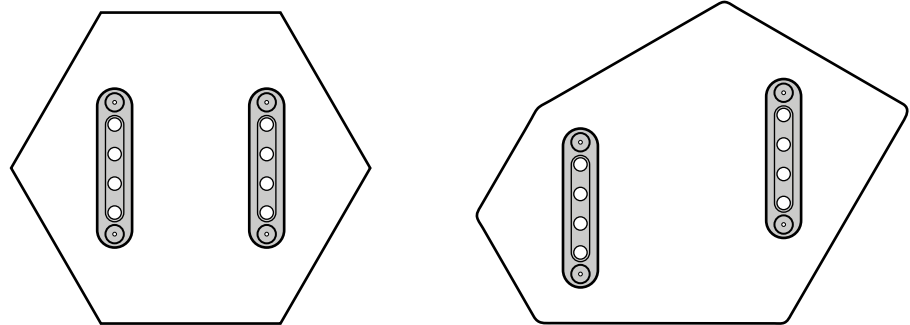
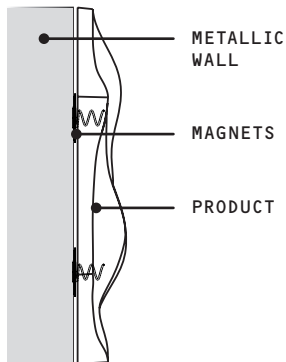

OPTION 2 //

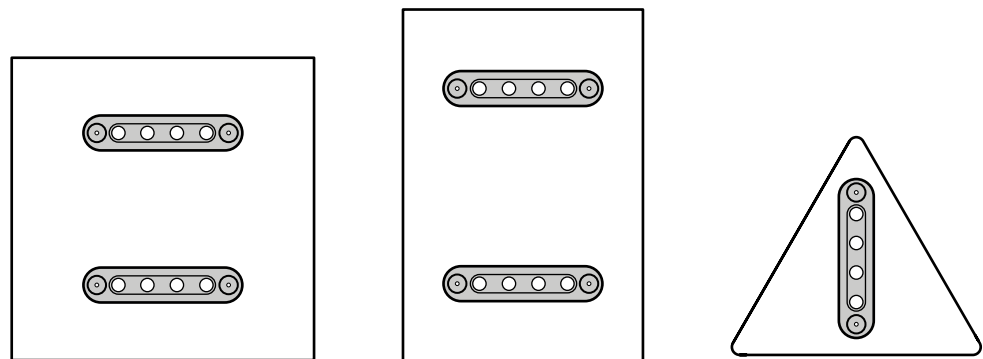
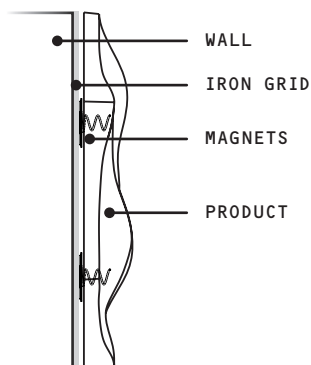

Guidelines

Before starting, read and follow the General Instructions in this document, the guidelines for Glue application and the Care & Maintenance Instructions available on Mogu website.

1. Test your composition on a clean floor, choosing your favorite arrangement;
2. Create a grid of iron beams, or, alternatively, the metallic tape supplied by Mogu, checking the alignment by using a level;
3. Simply position your the first product and check correct alignment;
4. You can now continue with your composition by simply taking the side of each hexagon as reference!

The magnets allow for easy positioning and future rearrangements of composition. Whenever you wish, you can always change the position of each product!

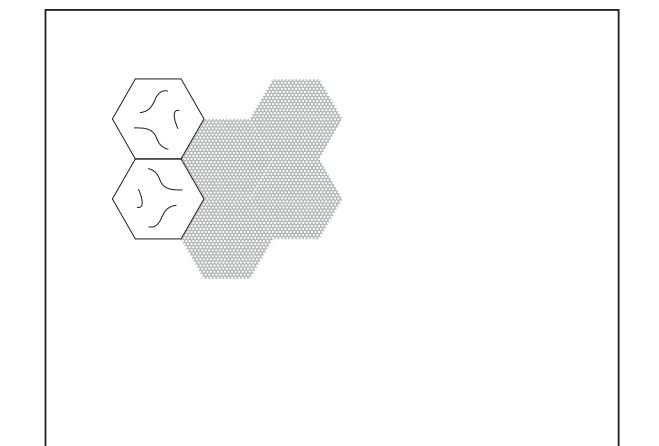

Modular grids

WAVE HEX

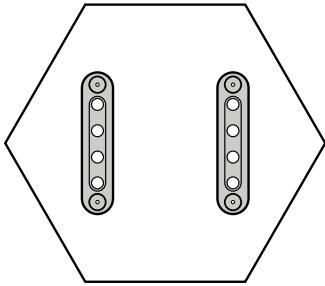

MODULE (X2 WAVE)

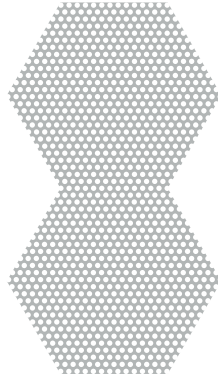

SYSTEM EXAMPLE

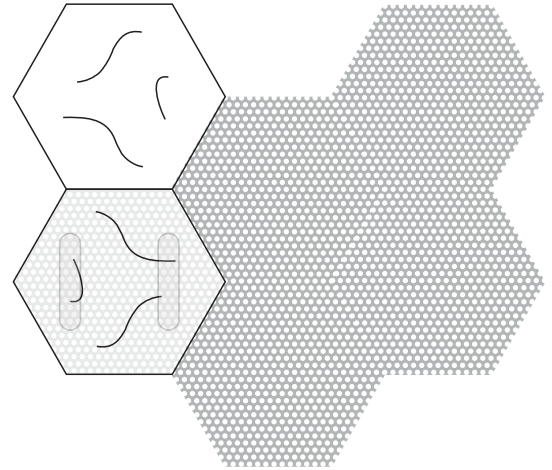

KITE & PLAIN 50/60

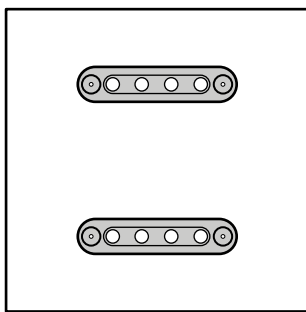

MODULE (X4 KITE/PLAIN)

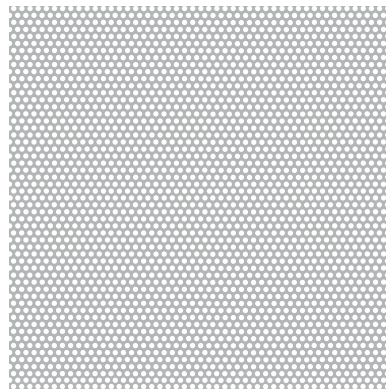

SYSTEM EXAMPLE

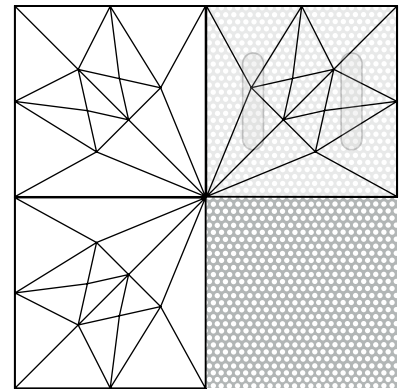

FIELDS

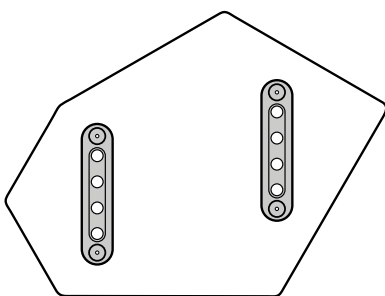

MODULE (X3 FIELDS)

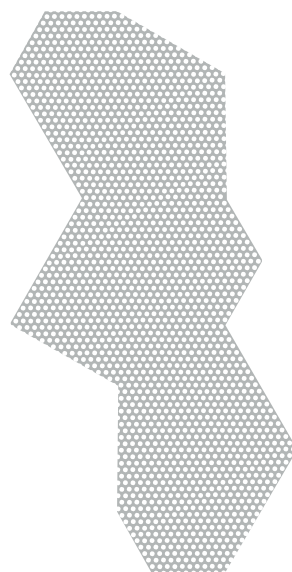

SYSTEM EXAMPLE

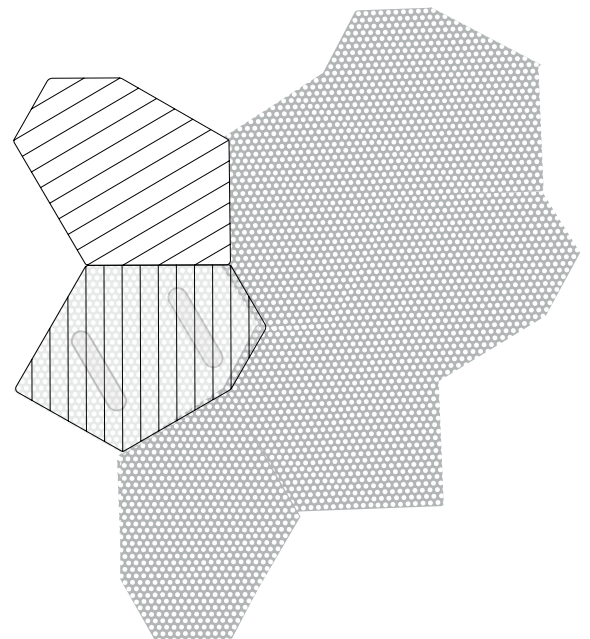

Fastening Strips Installation

Velcro fixing system

Mogu Acoustic panels can be supplied with the adhesive strips already fixed on the back for quick and convenient installation. It is necessary to remove the adhesive protection and attach the panel directly to the wall. After a few seconds, the panel will be perfectly fixed.

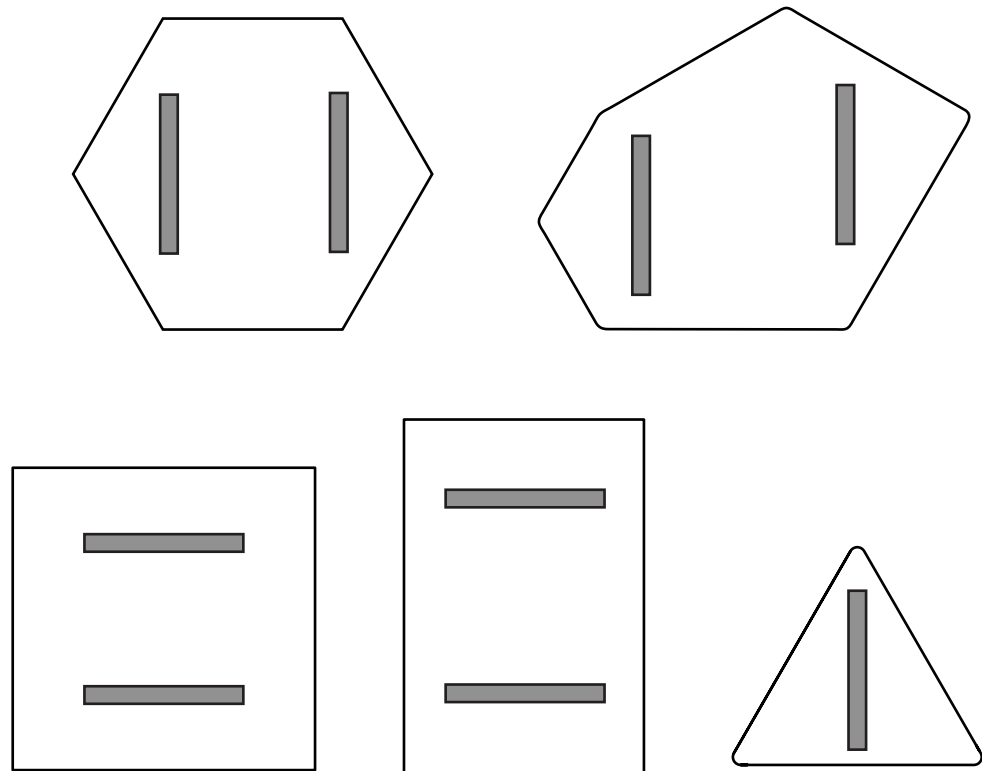
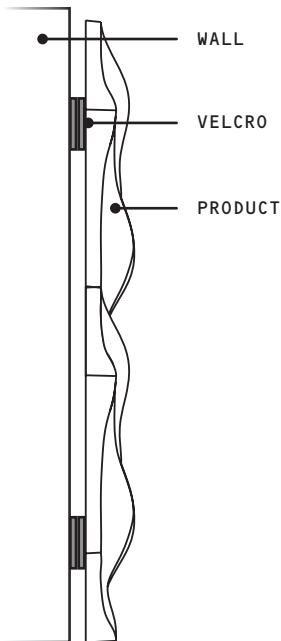

Guidelines

Before starting, read and follow the General Instructions in this document and the Care & Maintenance Instructions available on Mogu website.

1. Make sure the surface where you install Mogu products is clean, smooth, dry and free of dust.
2. Remove the adhesive protection and place the first panel without applying too much force.
3. Apply gentle pressure to the material for approximately 10 seconds.
4. You can now continue with your composition by simply taking the side of each hexagon as reference!

N.B. It is advisable not to remove the panel more than two times as it may alter the adhesion between the strips.

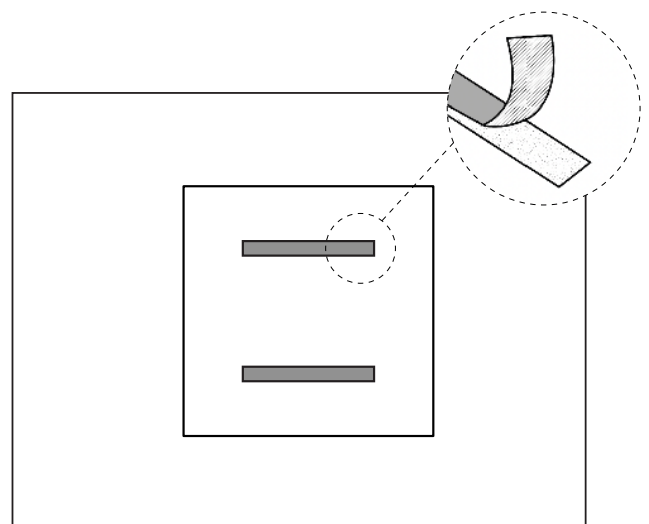

Ceiling System Installation

Screw fixing for Ceiling Installation

Mogu Acoustic panels can be installed also as a ceiling installation. Standard commercial profiles and ceiling kit systems can be adapted very easily to our screw (A) or magnetic (B) fixing system. Both systems are very easy to assemble and install on-site, to create stand-alone, cloud-like installations of acoustic panels. The option A works easily as the panels are mechanically fixed through screws directly to the commercial profiles.

OPTION A //

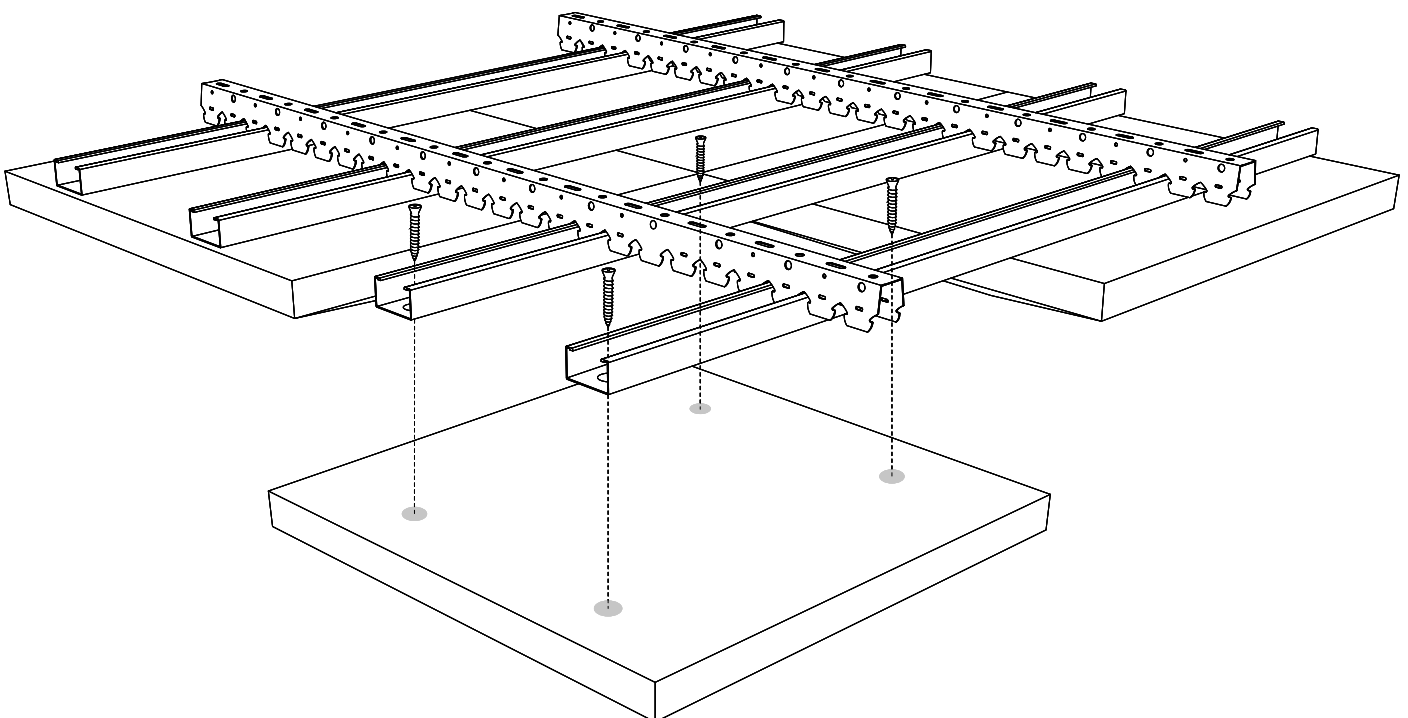
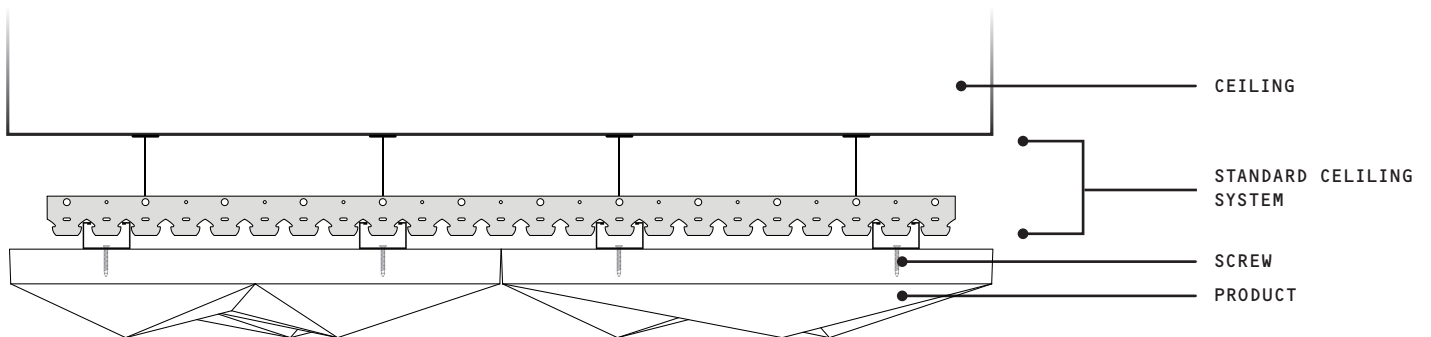

Magnetic Fixing for Ceiling Installation

The magnetic version should be chosen in case the acoustic tiles should be removed often, e.g. for inspection or maintenance, or for specific exhibition needs. It is based on the combination of our magnetic fixing system and standard commercial profiles available on the market. Compared to the wall application, the magnets used for ceiling application feature a higher magnetic strength, to grant perfect and solid adhesion.

OPTION B //

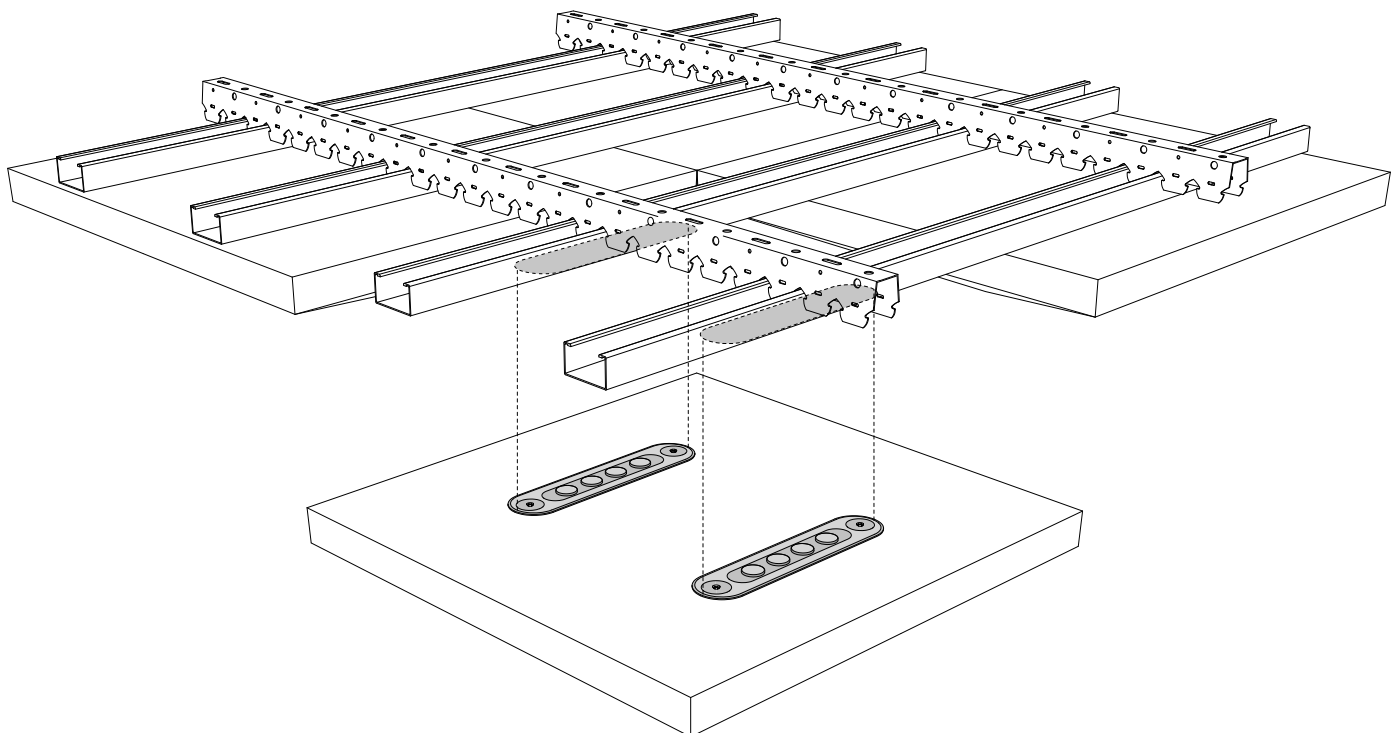
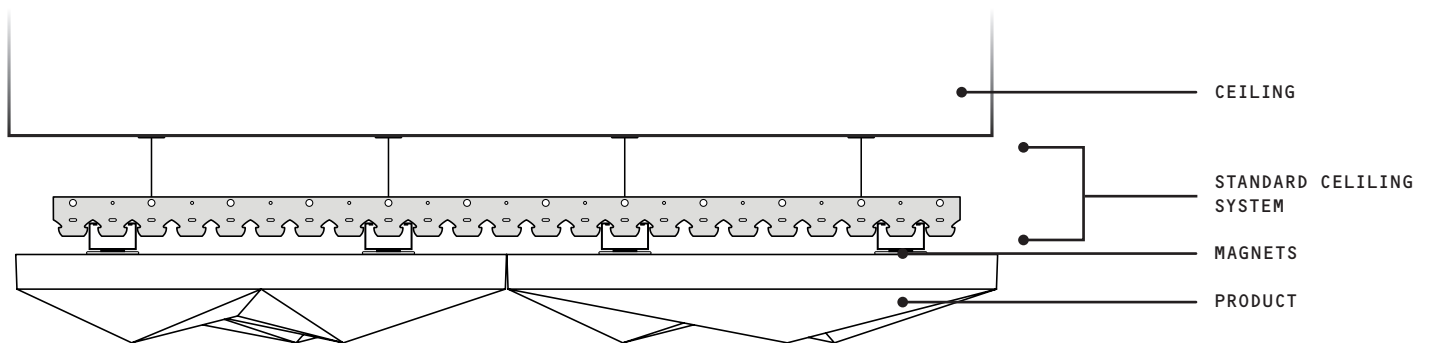

Care & Maintenance

Take care of your panels

Remember that sunlight affects any material; therefore, we suggest you to protect your products from direct sunlight and to bear in mind that even materials with good light resistance may fade in time. Take care to always protect your products from liquids and dirt. Always clean up spills immediately, by gently padding the product's surface with a clean towel.

Cleaning Instructions

Mogu products offer a unique experience provided by their outstanding innovative character. Their surface, either painted or natural, is delicate, be sure to read the following instructions before cleaning and attend to them carefully. Mogu products are naturally antistatic; hence they will accumulate little, almost no dust over time. Clean them only with a sweeper. Refrain from using a vacuum cleaner, in order to avoid damaging the product and its delicate surface.

Mogu Acoustic panels are not watertight. We discourage using any wet material to clean the products. Do not use wet mops, wet scrubbers or steam cleaners as these products may cause irreversible discoloration and damages. Do not use wax, polish, oil soap, abrasive cleaners, steel wool, scouring powder, or any appreciable amount of water. Never use solvents on the materials. Avoid spilling any liquid on the panels. In case of spillage or small stains on the painted panels, however it is possible to remove it easily thanks to Mogu's unique coating. Let the product dry, leaving it open air until no moisture is visible on the product. Do not rub the panels, because this may damage the fibres composing the material.

Product Durability

Mogu Acoustic panels are naturally hydrophobic. However, as it applies to all natural materials, including the wood components of humidity affects the product properties. Never install Mogu products on walls exposed to excessive humidity. Do not expose Mogu products to non-aerated environments. Your newly installed Mogu products are made from natural mycelium and therefore are subject to change from excessive moisture or nonconforming environmental conditions. Remove any standing or trapped water immediately and maintain an indoor relative humidity level below 50% throughout the year. We recommend the usage of Mogu materials only for living environments, and not in kitchens, bathrooms or cellars. Do not scratch, punch or rub the surface to ensure long lasting durability.

Repair & maintenance

Any repair and maintenance services must be performed exclusively under MOGU's personnel supervision or by personnel trained and authorized by MOGU. For safety purposes, only original parts may be used for replacing parts relevant to safety (e.g. the timber framing or the fixing system).

Customer Support

In case of further questions about your Mogu product and about how to look after it, please contact support@mogu.bio. For more information about Mogu and our extended line of products, visit us at www.mogu.bio

Contacts

If you have questions
related to the maintenance
of your new Mogu product,
please feel free to
contact us at:

support@mogu.bio
enquire@mogu.bio

Mogu was founded on the belief that it is possible to employ Nature's intelligence to radically disrupt the design of everyday products, seeking a finer balance between the man-made and the rhythms of the natural ecosystem.

Mogu products are obtained by growing mycelium, the vegetative part of mushrooms, on organic fibres (low-value residues from agro-industrial value chains).

The products are the result of five years of continuous and iterative R&D on mycelium technology, guided by a strong product-driven approach.

